

## **Prospects of Concentrated PhotoVoltaic (CPV) System in Wadi El natron Area, Egypt.**

KhaledFetyan<sup>1</sup>Osama Salem<sup>2</sup>

### **ABSTRACT**

This paper aims mainly to outline the features and design aspects of a pilot project to use stand-alone concentrator photovoltaic (CPV) technology to supply electrical energy for pumping underground water in the Egyptian desert (Wadi Elnatron) and running a salt water RO desalination system. This project is considered a large scale rural development projects in the Mediterranean region (Northern Egypt). The building unit of this project is a 30 KW CPV–water-pumping system capable of providing water enough to irrigate 120 acres of land from a single well. One significant goal of this project is to join together the European owners of the most advanced CPV technology, with respect to the state of the art, in order to investigate and unveil all possible sources of failure of their early commercialized products. Thus this paper clarifies the design aspects of all important elements of the project including the electrical load demand, the water load demand, the PV selection and sizing, and the environmental impact issues.

**Keywords:**solar energy, photo voltaic technology, solar irradiation.

### **1. introduction**

It is well known that solar energy is the original source of all renewable energy supplying the global world. The sun transmits a continuous power of about 172500 TW to the globe and about 70% of this power penetrates the terrestrial sphere and becomes the main source of power origin necessary for different activities and natural phenomenon.

World's energy strategy must therefore comply with this trend and introduce clean renewable energy sources in their power generation policy. The Egyptian Government is of no exception: they believe it is imperative to introduce large scale PV power stations especially in the clean and new cultivated areas. This pioneer step gains the advantages of protecting the environment and helping the economic growth when these new communities and villages are electrified. The government in fact believes in further future development as they conceive a design for PV station interconnected to the national network grid. From this point of view, a project for Concentrated Photovoltaic (CPV) in wadi elnatron has been established with The European Commission consists of seven partners

The main goal of this project is to bring together the owners of the most advanced European CPV technology, with respect to the state of the art, in order to research from their leading position new applications for CPV systems. In addition to opening up new markets, this research will unveil possible sources of failure in new environments in order to assure component reliability. The main objectives of the project are: a) Installation of a Stand Alone CPV system in wadi Elnatron area of Egypt, b) Implementation of normative and a worldwide database on CPV systems, c) Improvements of CPV components technology and development of a new CPV system, and d) examine the perspective and the concept of this new project including technical, social, environmental, economic, and financial views.

### **2. justification of the project**

Statistical records of Egypt confirm that the living community occupies only a narrow green valley along the river Nile's boarder. The land being occupied is only about 5% of the total surface area which will never comply with the ever growing population of the country.

---

<sup>1</sup>[Researcher ], [Mechanical&ElectricalResearchInsitute, National Water Research Centre(NWRC), Egypt.], [Delta Barrage], [khfetyan@yahoo.com] ;

<sup>2</sup>[Assistant Researcher], [Mechanical&ElectricalResearchInsitute, National Water Research Centre(NWRC), Egypt.], [Delta Barrage], [engosama\_87@yahoo.com]

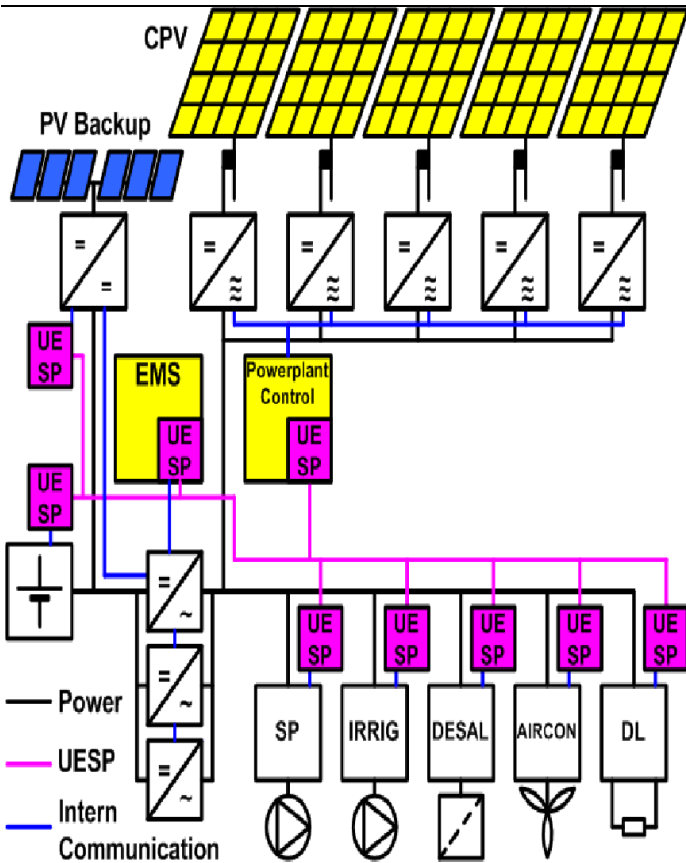

All these magnified problems have prompted the Egyptian Government to launch a huge national projects aiming to enter the renewable energy in all fields. Undoubtedly, all governmental organs along with private sectors will coordinate their efforts in order to bring this dream to the light.

So a project with the European Commission has been built, the site selected for the project is ideal; it is in the north south part of Egypt (wadi El natron) where the irradiation is at the highest level in the country. In addition the underground water based on the scanning of the Ministry of Water Resources and Irrigation is abundant. All of these vital geographic and meteorological parameters made the selection of the site meet the required economic aspects for the project. The project is multidiscipline management supported by the Mechanical and Electrical Research Institute (MERI), National Water Research Center (NWRC), Ministry of Water Resources and Irrigation.

The system consists of an electrical and a hydraulic part. The hydraulic system is built with AC loads, the submersible pump (SP) conveying water out of a well into a storage tank. The irrigation pump (IRRIG), pumping water out of the storage tank for irrigation and a desalination unit (DESAL). As the water is only slightly salty it is good enough for irrigation but for drinking it has to be desalinated.

On the electrical side bi-directional island inverters are forming the three phase grid. On the AC side the Concentrix CPV trackers are feeding in. Loads are the pumps, the desalination unit, the irrigation pump, an air conditioning (AIRCON) for cooling the battery room and a dump load (DL) for passive control of excess power. On the DC side a battery provides power for the monitoring and measurement as well as the tracking system of the CPV. Through a charge controller a small flat plate PV is coupled to the DC bus. This flat plate PV functions as a backup system to deliver the power to track again the CPV modules into direct sunlight after a long period without direct irradiation.

The heart of the system is the intelligence of each component and their ability to communicate with each other and the supervisory energy management system via the Universal Energy Supply Protocol (UESP).Therefore a communication bus connects each component over a CAN bus. Each component collects data, for example tank level, water flow rate, power, current, etc. All components may have access to this data. The system's work could be explained as follows:

The NACIR system consists of five CPV trackers with each 6 kw, together 30 kw, a 903Ah at C10h conditions lead acid battery storage provides energy for measurement, the power plant control as well as the EMS during night and around two days without direct sun. A 1 kw flat panel PV system function as a backup in case of empty energy storage, to get the CPV again tracking the sun after a long time without direct sun. The flat panel PV is DC coupled with the battery through a charge controller. Three stand-alone inverters are building up the 3phase island grid connecting the battery and the DC coupled flat PV with the three phases Concentrix CPV inverters and the AC loads. The CPV is linked via standard grid connecting inverters to the tree phase island grid.

For the realization of an optimized operation of the off-grid CPV water pumping, desalination and irrigation system the so called Universal Energy Supply Protocol UESP [UESP: Universal Energy Supply Protocol - Development of a universal management system with an open system architecture, supported by the German ministry for environment developed at Fraunhofer ISE, is used. It allows an optimized integration of the advanced power conditioning system into the NACIR system in Egypt [1].

### 3. Strategy of the Egyptian government

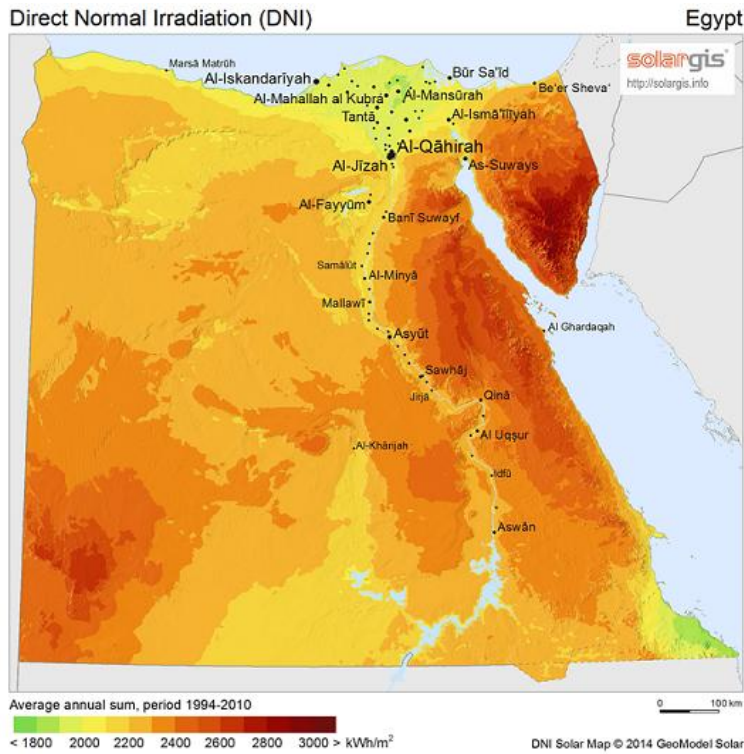

Map of Solar Irradiation Egypt

Limited water resources and scarcity of water in Egypt is the main challenge for the Egyptian government. At the same time over population is rapidly increasing and agricultural land decreased. As a result, quantities and qualities of food decrease. To solve this problem adopted policies of horizontal expanding in agricultural lands and activities had been considered based groundwater to cultivate new Desert areas. one of this adopted policies is the 1 Million feddan project that will be in the Egyptian desert, depending on underground water for irrigation [2]. From this point of view, energy is one the most important factors for this new project especially the renewable energy (solar energy) as Egypt is one of the most countries that has high intensities of solar radiation and longer durations of sunshine hours and is endowed with abundant solar energy and good weather conditions most of the year as shown from Map of Solar Irradiation of Egypt, thus we will explain the elements of designing a PV station;

#### 3.1 Sizing the PV

The basic equations necessary for sizing the PV station are summarized [3, 4] in the following fundamental relations:

$$\text{Energy balance: } I \cdot A \cdot \xi_{pv} \cdot K = E_d \cdot D_{pv} \cdot R \quad (1)$$

$$\text{Efficiency: } \xi_{pv} = P_{pv} / (I_r \cdot A) \quad (2)$$

$$\text{Sizing : } P = E_d \cdot D_{pv} \cdot R / [(I / I_r) \cdot K] \quad (3)$$

$$\text{Equivalent sunshine hours: } \Psi = I / I_r \quad (4)$$

$$\text{Energy : } E_{pv} = P_{pv} \cdot \Lambda \quad (5)$$

$$\text{System product in hours} = \Lambda \quad (6)$$

Where I is the in-plane insolation, I<sub>r</sub> is the reference insolation, K is the performance ratio, D<sub>PV</sub> is the solar energy dependence, E<sub>d</sub> is the energy demand. R is the design redundancy, ξ<sub>pv</sub> is the PV efficiency, and Λ is the array area of the PV modules.

#### 3.2 Economical and financial analysis

Project costs depend heavily on the system size and the Egyptian specifications for the project. In addition, the total cost will depend whether the project is intended for a turn-key delivery or on the subsystem and components costs. However, the cost of electricity generated by a PV station depends mainly on

- 1- Site specification,
- 2- System efficiency.
- 3- Modules cost,

- 
- 4- Balance of system.
  - 5- Bank loans and interest rate
  - 6- System life.
  - 7 - Operating and maintenance cost

Many publications reviewed different methods of estimating the per unit kWh cost produced by PV system. It can be shown [5] that the cost of the kWh energy produced from the PV system may be given by

$$\$(\text{per kwh}) = (\alpha.C) + \epsilon / E \quad (7)$$

$$\text{Where } \alpha = \text{annuity rate} = r(1+r)^n / (1+r)^n - 1 \quad (8)$$

C = total capital cost, \$ = annual running cost, E = annual kWh produced by PV system, r = net interest rate, n = number of years useful life

It is clear that sites with higher insolation and systems with lower components cost and longer lifetime will result in reduction of the electricity cost.

### 3.3 Selection of Photo-Voltaic Technology

A series of commercial modules are commercially available with high technology and an expected lifetime of 20 - 30 years. The best modules efficiency ranges between 15% to 16%, but the commercial efficiency available is about 14%. The feasibility study confirms that poly crystalline silicon modules are the proper selection because of its high overall efficiency, reliability, stability, and market prices.

## 4. Discussion and conclusion

- A pilot project to use stand-alone concentrator photovoltaic (CPV) technology to supply electrical energy for pumping underground water in the Egyptian desert (Wadi El natron) is proposed and presented. Although the project has advantage of high reached power as it is tracking the sun all over the day depending on the direct sunshine, it has a lot of disadvantages such as it depends only on the direct sunshine that mean if there is a cloud there is no output power, high and difficult programming control that considered the tie of all component of the project, difficulty in getting any component of the project as it isn't considered as commercialized product.
- The policy of Egyptian government is very encouraging towards the installation of clean large scale PV power station at the new lands. one of this adopted policies is the 1 Million feddan project that will be will contribute in increasing the cultivated lands, agriculture production and the new job for the new generations. The project will enable the Egyptian country to utilize the available sun power in most effective way and releasing the unified network from supplying the new remote areas. In addition to the fuel saving and the suppression of the CO2 gas emission in the environment.

## REFERENCES

1. NACIR Final Project Report, MERI, NWRC, Egypt, 2012.
2. Strategy of the Egyptian Government assessment, phase 1 million feddan, 2015.
3. K. Kurokawa, 1998. Realistic values of various parameters for PV system design. World Renewable Energy Congress, September 10-25, Florence.
4. W. Platz et al, 1991. Energy pay-back time of photo voltaic modules. Int. J. of Solar Energy Vol. 10, 211-216.
5. K. Kurokawa, 1997. Area evolution of PV system. Solar Energy Materials and Solar Cells, Vol. 47, 27-36.